

# SEMI-AUTOMATIC WASTEWATER TREATMENT

## Ringwood 200-SA

Ringwood's wastewater treatment units optimize the use of clay based flocculants to clarify industrial wastewaters.



### Standard Features:

- Semi-Automatic operation with manual overrides
- Maximum throughput 400 GPH
- 200-gallon treatment tank
- Allen-Bradley controls
- UL approved control panel
- 1 horsepower heavy duty agitator with jet basket
- Single addition automatic chemical feed hopper
- Bandfilter roller for greater dewatering
- 1/2 Cubic yard dumpster included
- Access platform included
- Stainless steel construction standard
- Equipment Measurements: Length: 9'0" Width: 5'8" Height: 8'2" Weight: approximately 1500 lbs.

### Optional Features:

- 2" Cast Iron Influent Diaphragm Pump
- Effluent Sump & Pump Package
- Equalization and Reuse Tanks

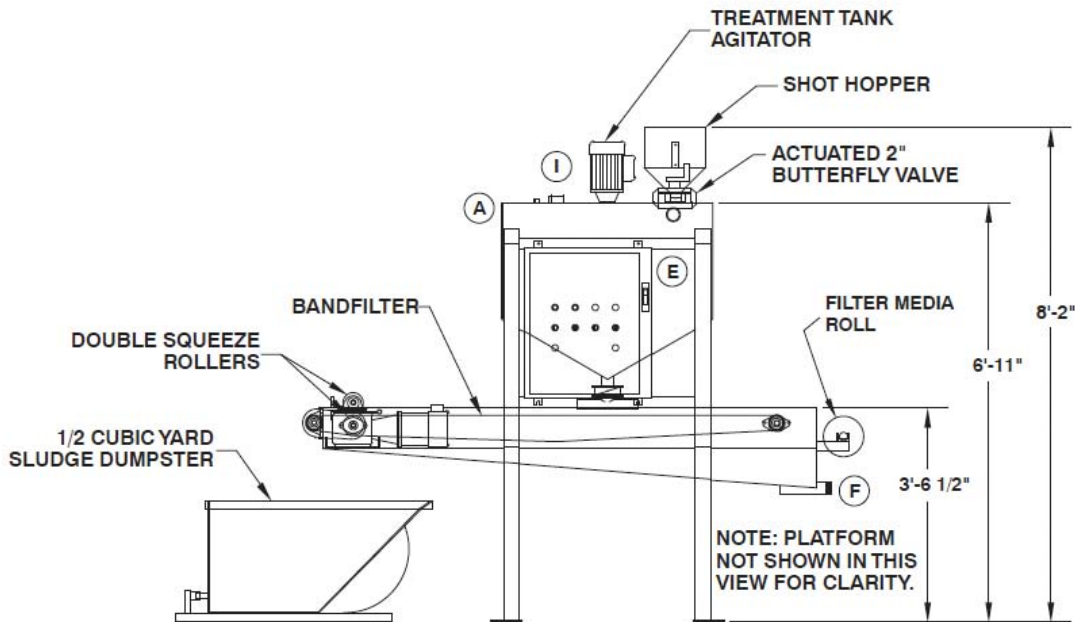
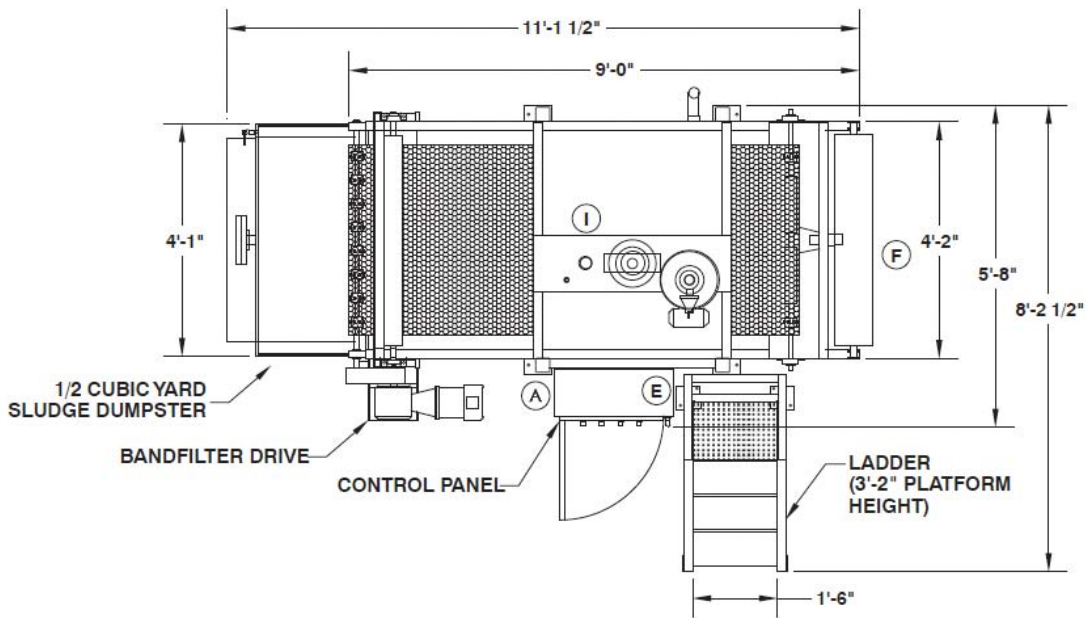

## Service Requirements:

- E** 480 VAC, 15 AMP, Grounded, 3 Phase Power Terminated at the Disconnect in the Control Panel.
- A** 1/2" FNPT Air Supply Connection. 80-100 PSI, Clean, Dry, Air Required With Locking Handle Valve on Service Line.
- I** 2" FNPT Influent Water Inlet Connection.
- F** 2" MNPT Effluent Water Discharge Connection.

RCM Deburring, Inc.  
26893 Bouquet Canyon Rd.  
Suite C-172  
Santa Clarita, CA 91350

www.rcmdeburring.com  
email: sales@rcmdeburring.com  
telephone: 661 • 296 • 9611  
fax: 661 • 296 • 9184