

MANUAL WASTEWATER TREATMENT

Ringwood TT-200

Ringwood's wastewater treatment units optimize the use of clay based flocculants to clarify industrial wastewaters.



Standard Features:

- Economical with Small Footprint Manual System
- Maximum Throughput: 400 gph
- 200-Gallon Treatment Tank
- 200-Gallon Clean Water Tank
- 1/2 Cubic Yard Dumpster
- U.L. Approved Control Panel
- 1-1/2 Horsepower Heavy Duty Agitator with Jet Basket
- Driven Bandfilter with roller for greater dewatering
- Equipment Measurements: Length: 6'2" Width: 5'2"
- Height: 7'5" Weight: approximately 1,300 lbs.

Optional Features:

- Influent Pump
- Effluent Pump
- Stainless Steel Construction

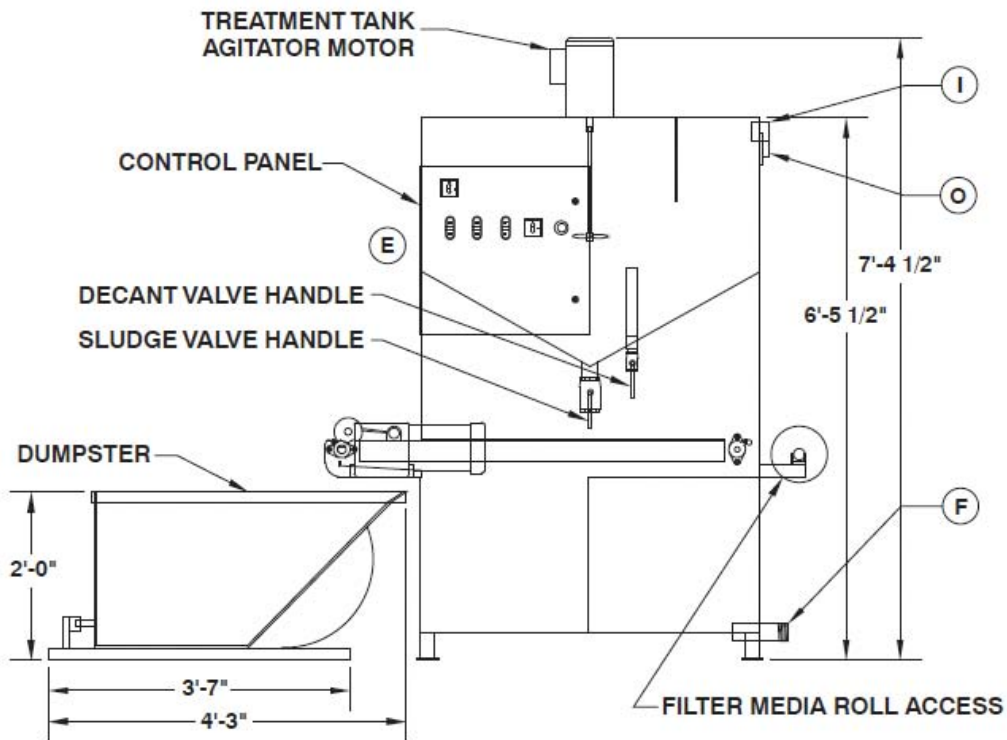
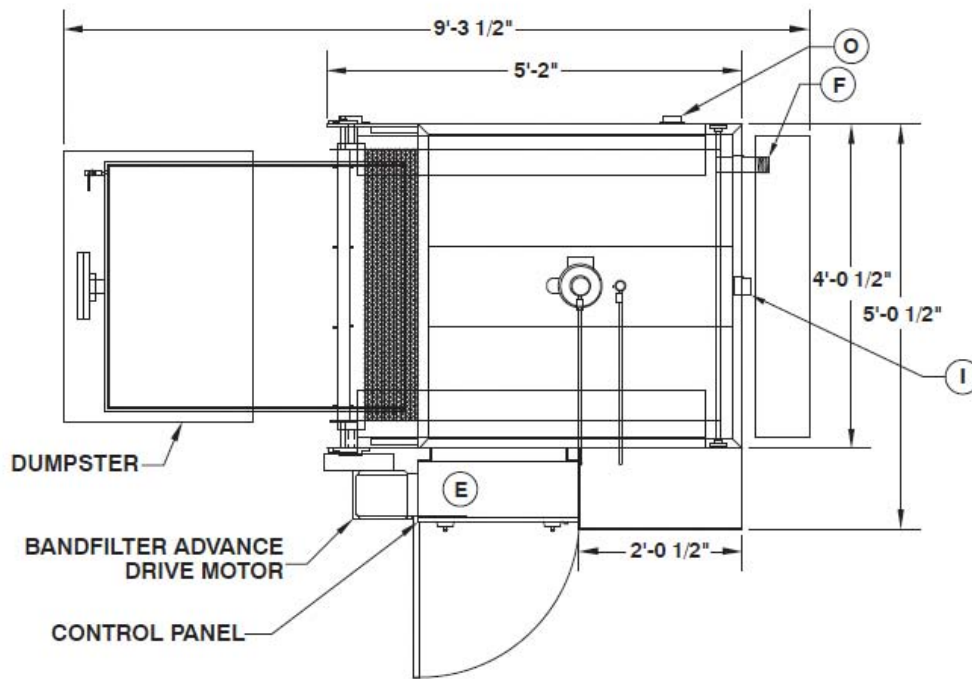

Service Requirements:

- E** 115 VAC, 30 AMP, Grounded Single Phase Power Terminated at the Disconnect in the Control Panel.
- F** 2" MNPT Discharge to Sewer Connection.
- I** 2" FNPT Influent Water Connection.
- O** 2" FNPT Treatment Tank Overflow Connection.

RCM Deburring, Inc.
26893 Bouquet Canyon Rd.
Suite C-172
Santa Clarita, CA 91350

www.rcmdeburring.com
email: sales@rcmdeburring.com
telephone: 661 • 296 • 9611
fax: 661 • 296 • 9184